

E C 1 V 7 N

antreas panagi
magcd - csm
autumn 2021

a research on how an image can be
translated into a diagram. the case
of rawstorne street, london.

CLERKENWELL

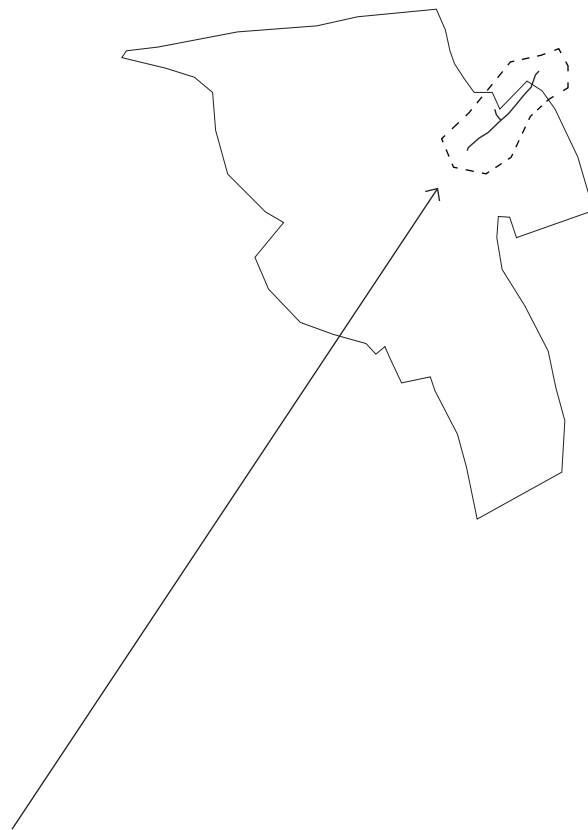

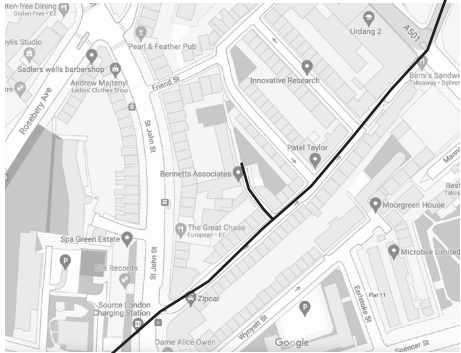

RAWSTORNE ST

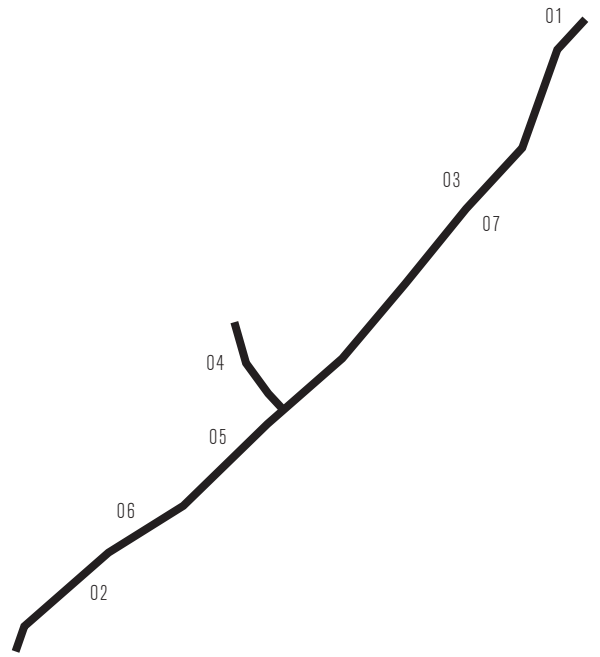



01

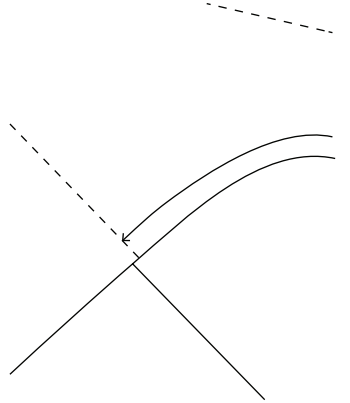

01

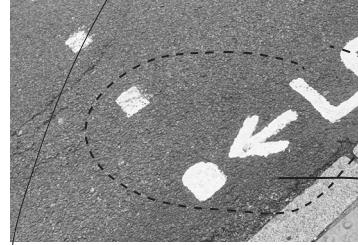
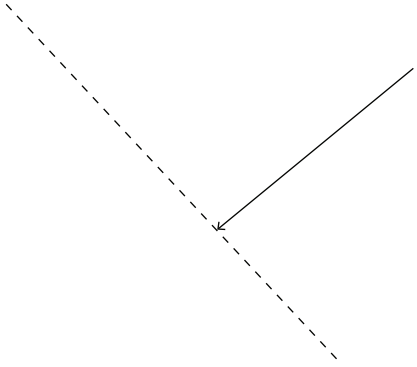

~~pedestrian~~
signs
dashed line
arrow pointing left



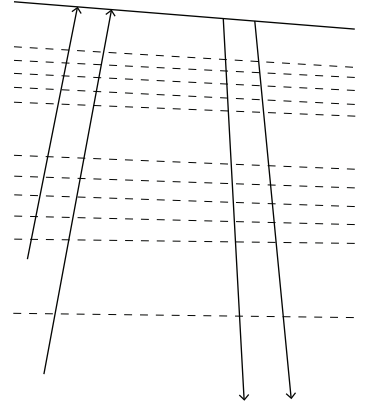

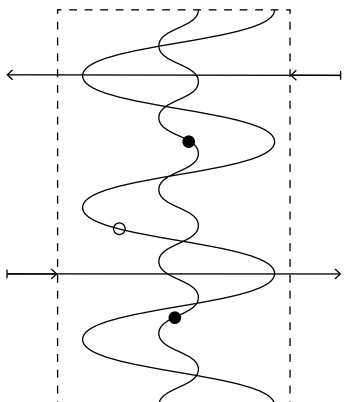

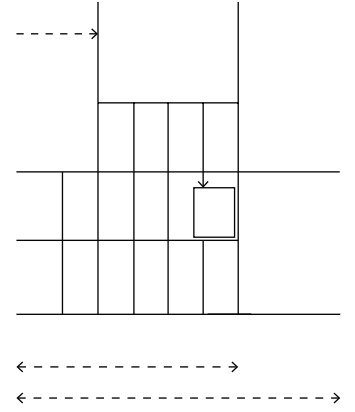

05

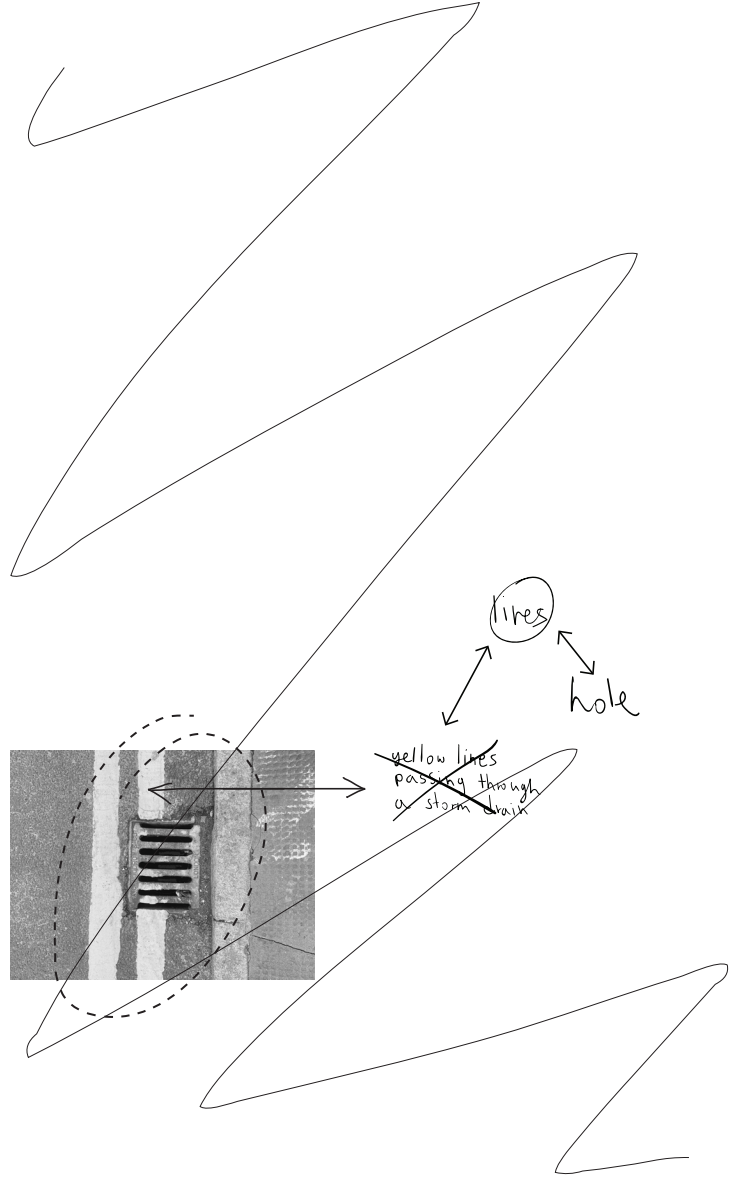
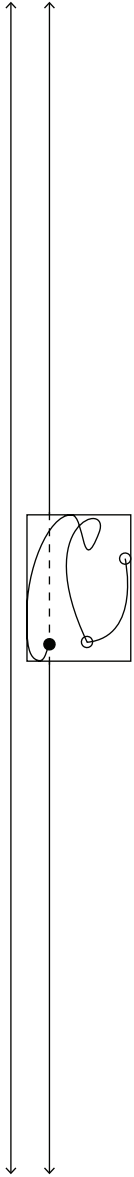

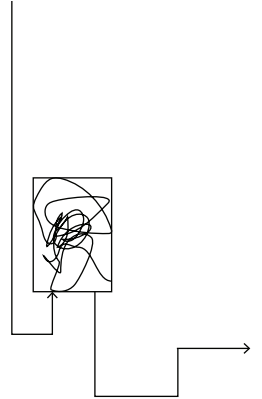

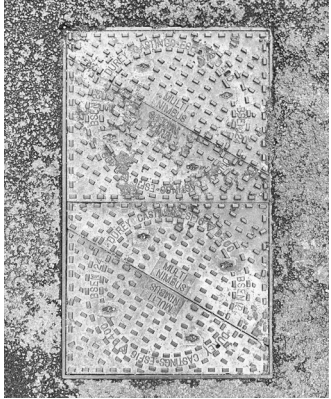

07

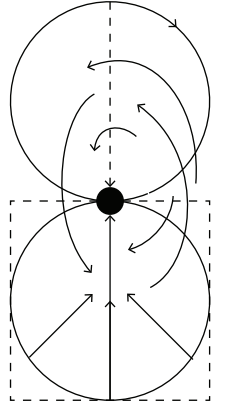

MEANWHILE



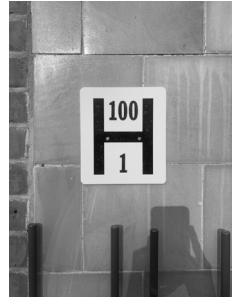
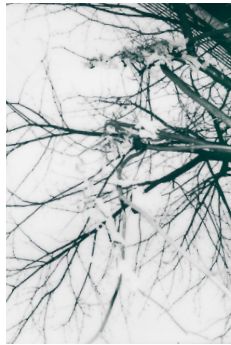
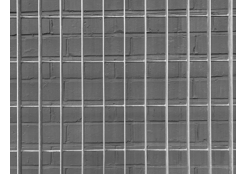
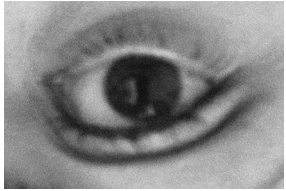

I'M LOOKING UP AT THE SKY WHILE I'M WALKING IN THE MIDDLE OF THE EMPTY STREET. IT'S FULL OF NAKED TREE BRANCHES REMINDING ME THAT I AM LOCKED INSIDE MY THOUGHTS—FEELING DISABLED—SURROUNDED BY A METAL CAGE. I FEEL THIRSTY, BUT THE WATER HYDRANT IS ONE HUNDRED METERS AWAY. MY HANDS ARE TREMBLING AS MY EYES BLINK.

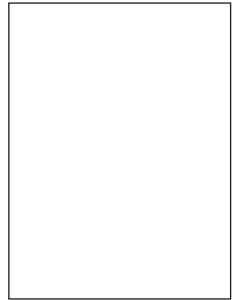
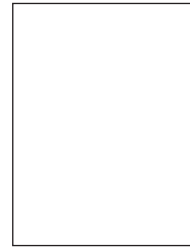
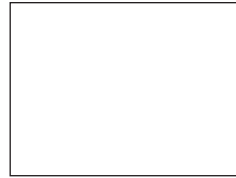
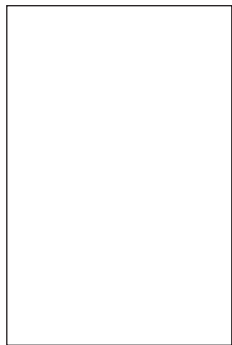
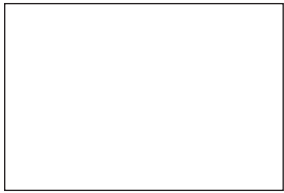

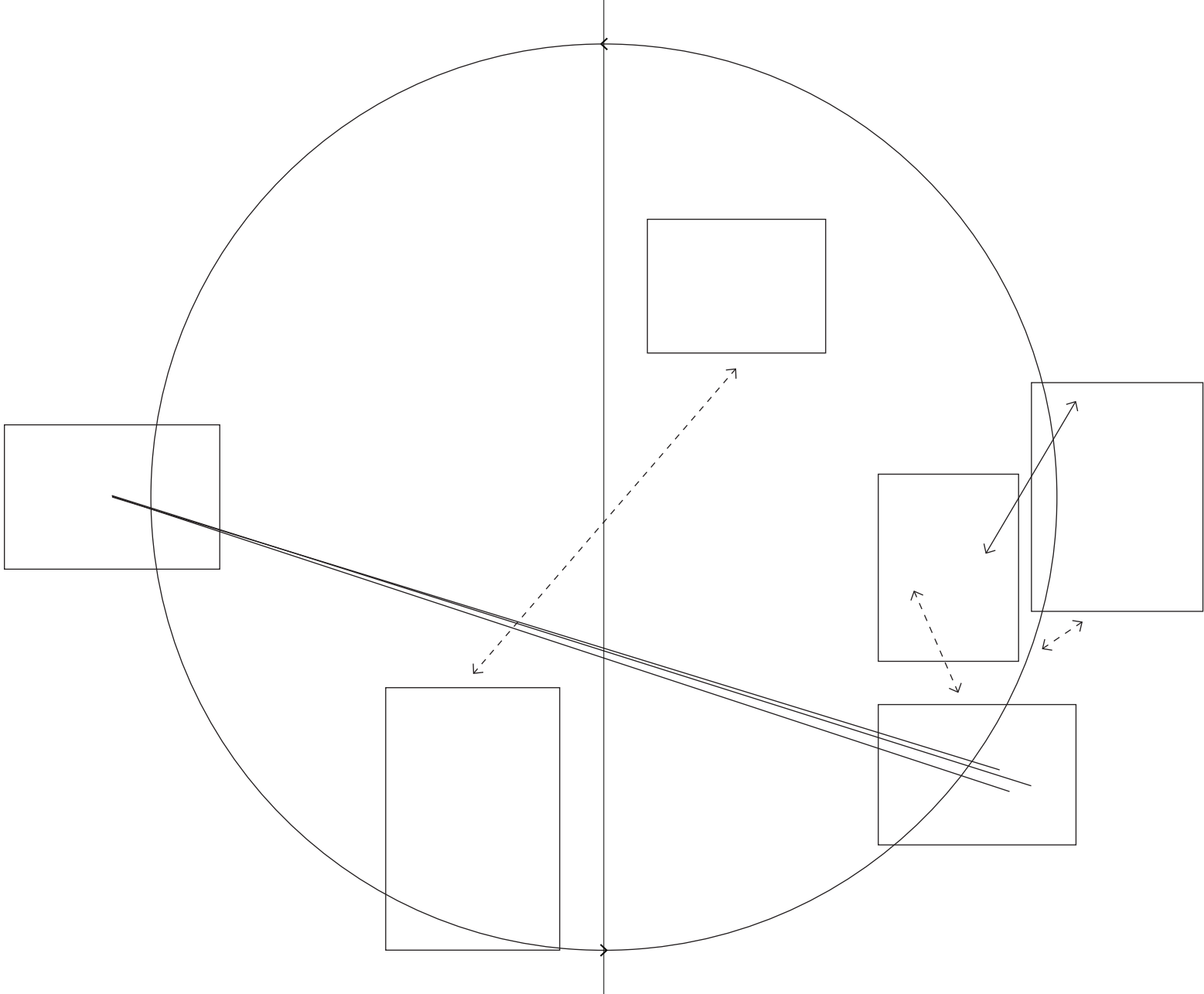

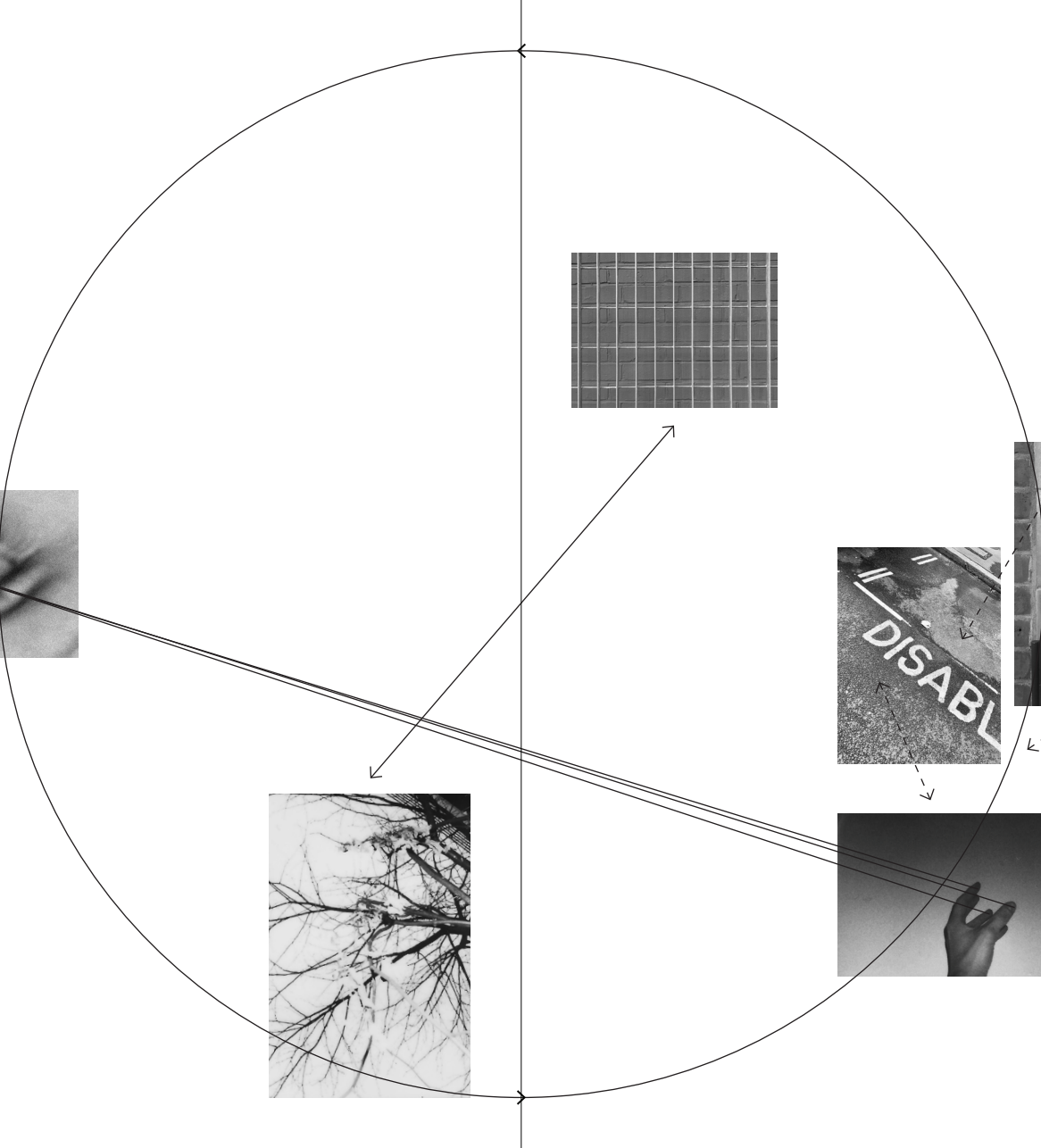
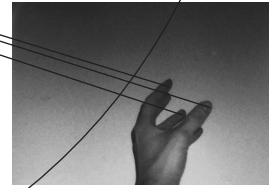
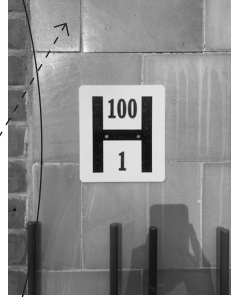
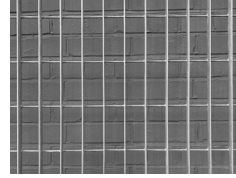
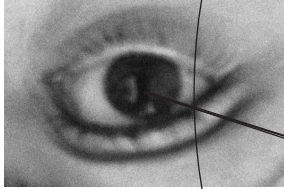

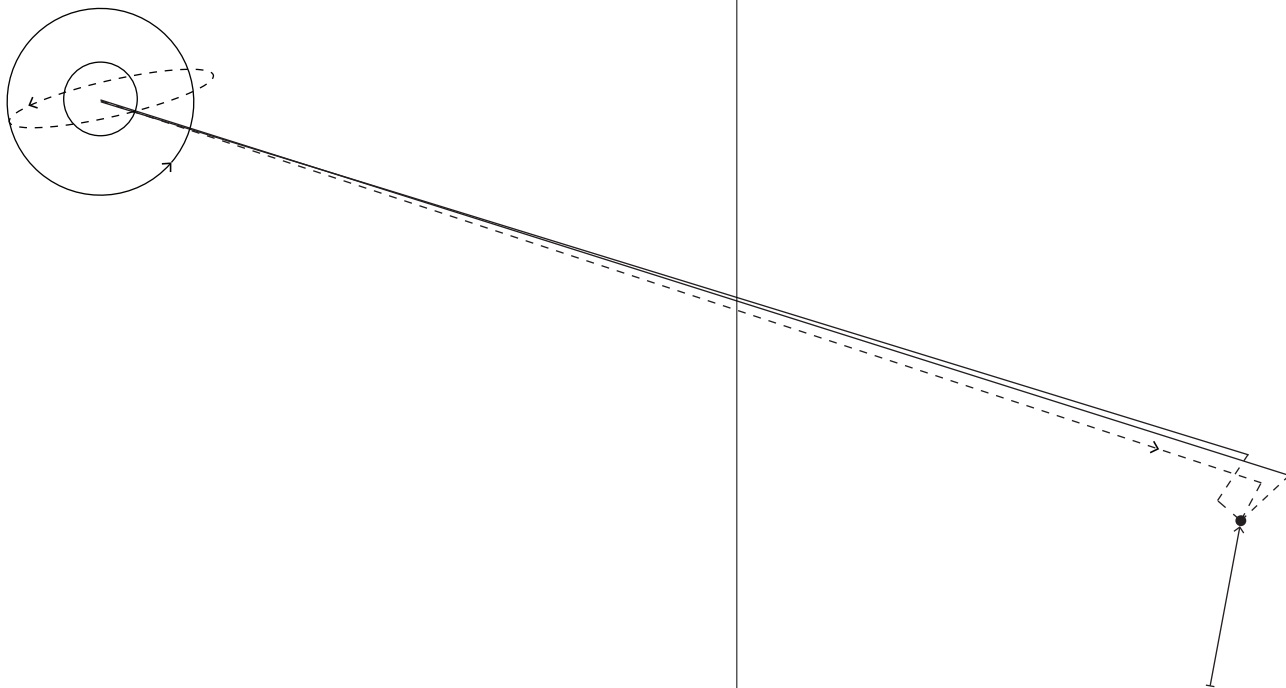

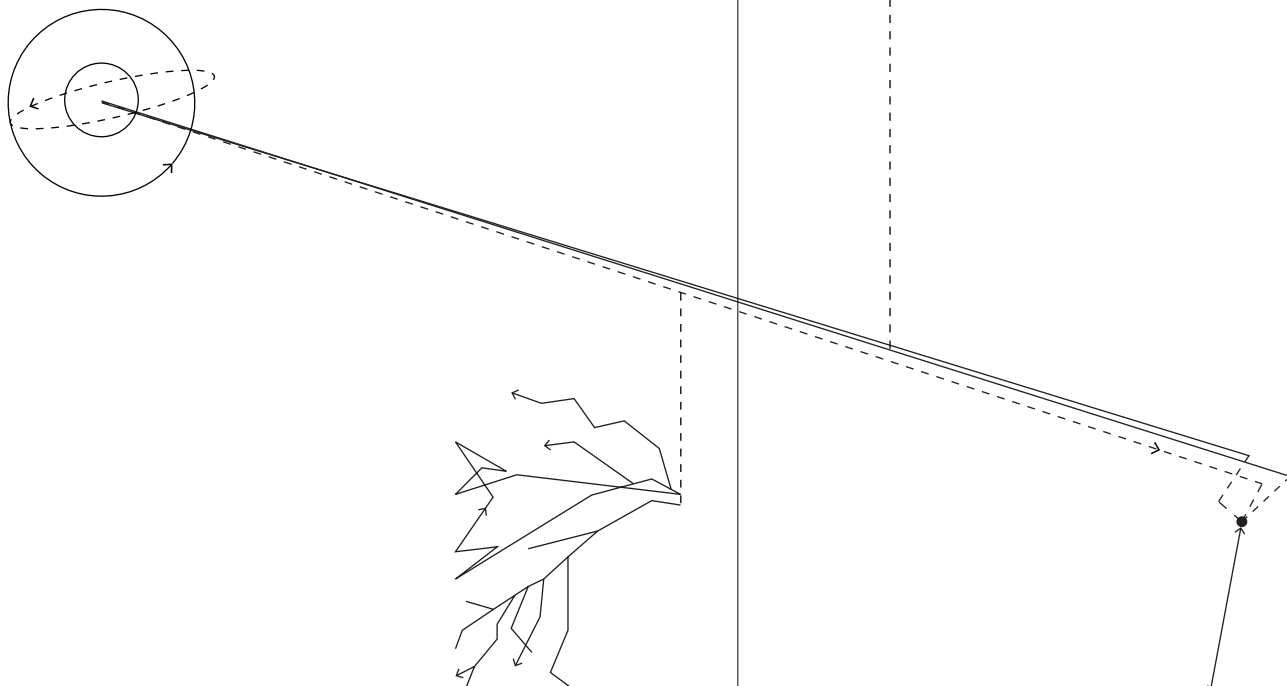
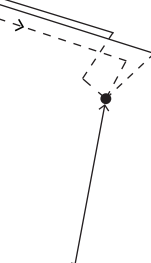
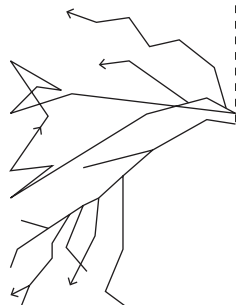
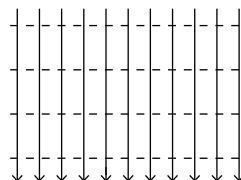
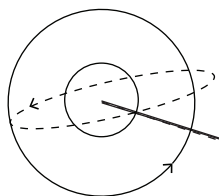

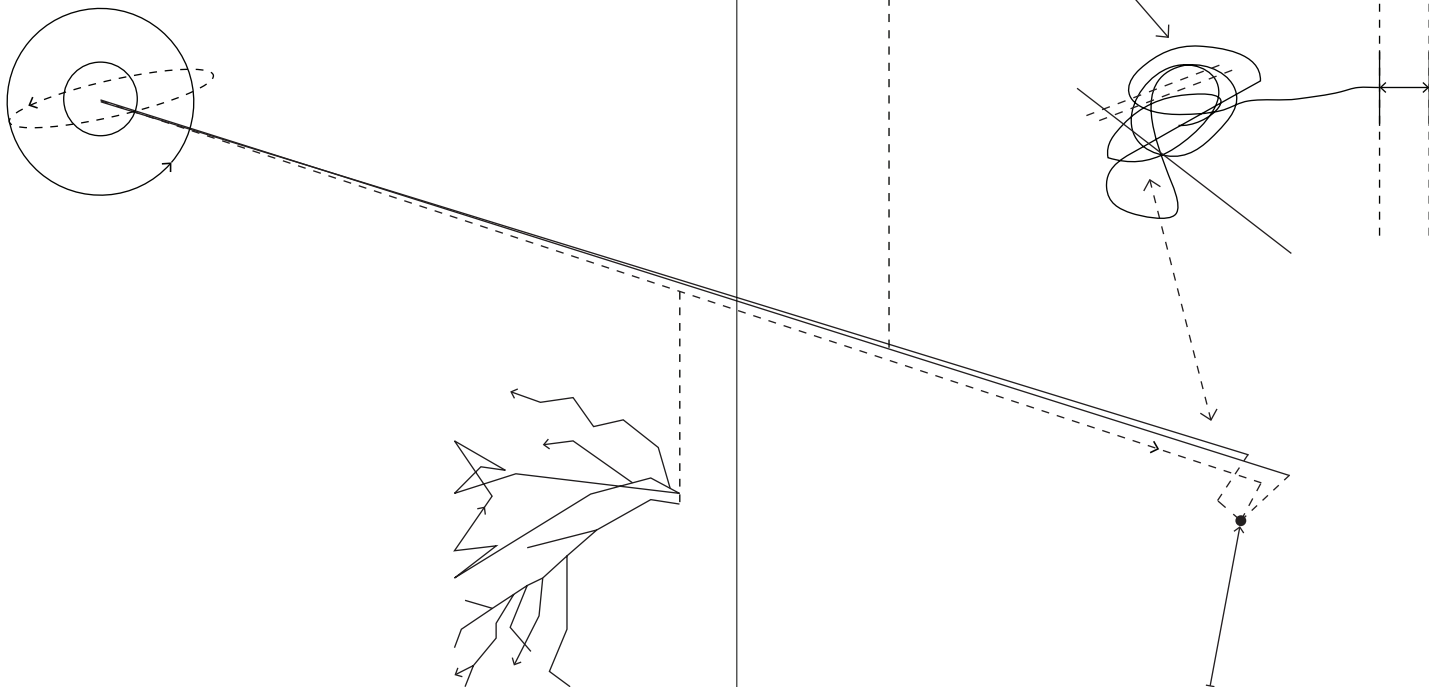
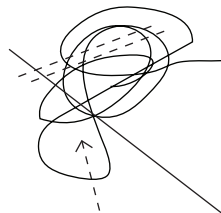
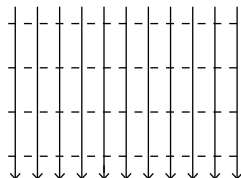
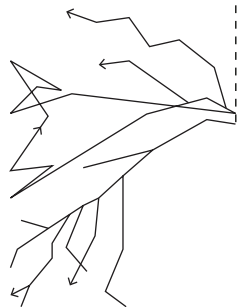
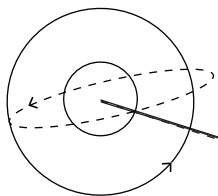

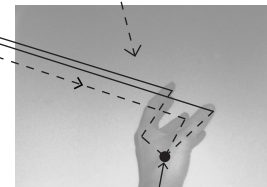
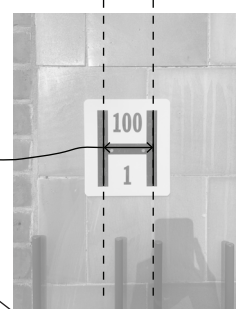
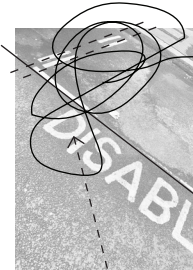
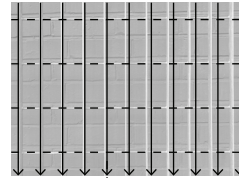
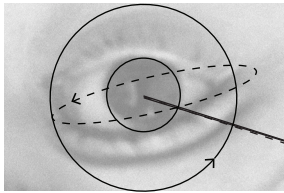
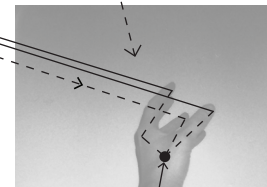
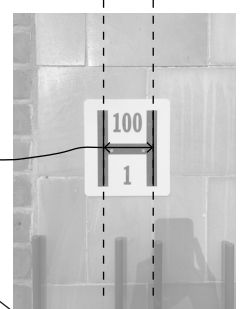
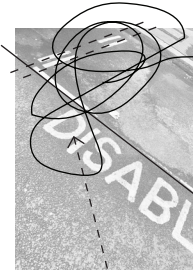
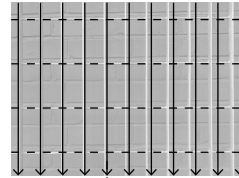
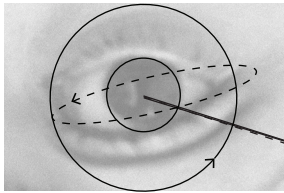

i'm looking up at the sky while i'm walking in the middle of the empty street. it's full of naked tree branches reminding me that i am locked inside my thoughts—feeling disabled—surrounded by a metal cage. i feel thirsty, but the water hydrant is one hundred meters away. my hands are trembling as my eyes blink.

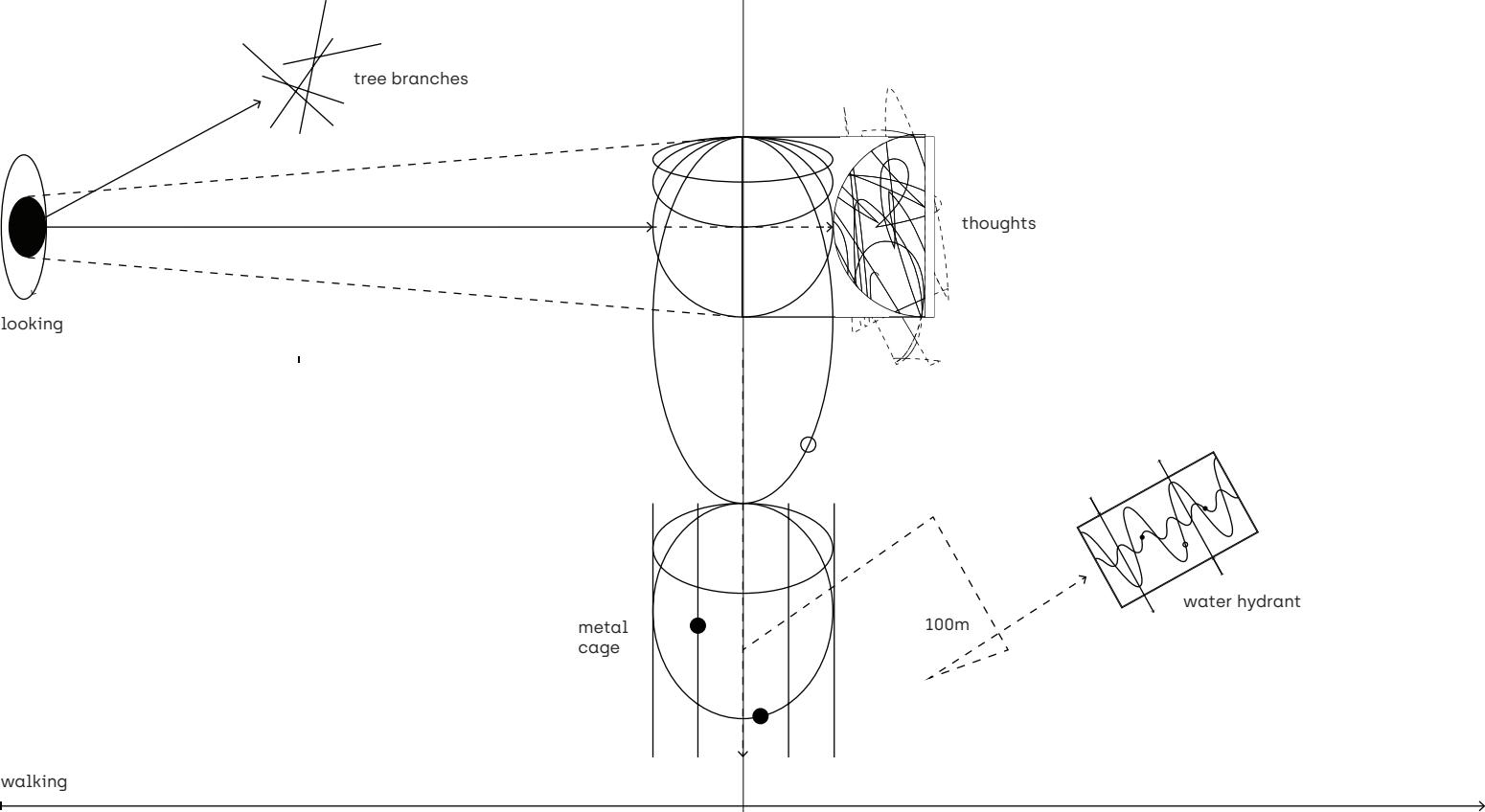

antreas panagi
Y2U2, magcd - csm
autumn 2021

